

Distribution box specifications xzm

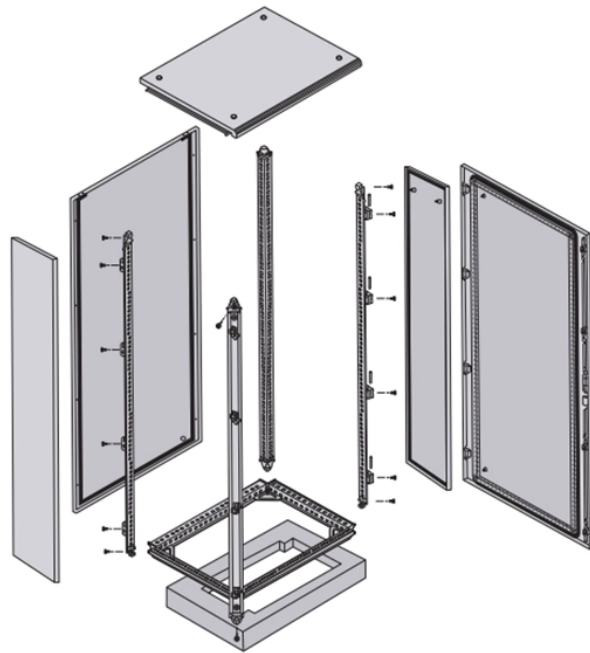

Distribution box specifications xzm



DC Micro Style Distribution Boxes Four-pin, One Signal per Port Cable Connector Distribution Box Eight-port DC Micro Distribution Box Specifications



This MINI® waterproof power distribution box has a Gore vent, relay retention grid, tool-style AssureLatch™, and IP68/IP69K ratings.



Metal Distribution Box Features Continuously welded seams Foam-in-place seamless gasket 120-degree opening heavy-duty industrial hinges IP66 protection rating against dust and water according ...



MICHELIN STABIL"X XZM The rugged pneumatic Michelin® radial tire is designed for forklift trucks, terminal tractors and other industrial equipment used in heavy-duty applications.



The Michelin XZM will always retain the same LONG LIFE ADVANTAGE irrespective of the types of surface it operates on. Energy consumption is reduced due to the lower internal losses within the tyre.



The heavy duty tread of the Michelin Stabil'X XZM radial forklift tire makes it resistant to punctures and damage improving productivity and reliability. The Michelin Stabil'X XZM is a rugged pneumatic ...



Find all the technical and commercial information you need in our product data sheet: Introducing MICHELIN XZM Port and airport vehicles, Heavy capacity forklift, ...



Find the technical and commercial specifications downloadable documents below. Get longer wear life and excellent protection with the radial technology of the MICHELIN® XZM® tire.

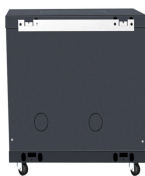

The shaded box of load/pressure tables is the value defined by the industry standards. Up to this limit, the tire works in an optimal zone leading to a better balance of performance. The use of MICHELIN® ...

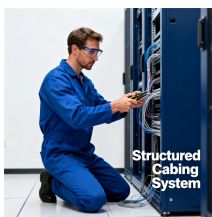

Find the technical and commercial specifications downloadable documents below. The MICHELIN® XZM® 2+ tire offers improved productivity with better robustness and comfort.

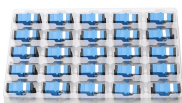

Find all the technical and commercial information you need in our product data sheet: Introducing MICHELIN XZM Port and airport vehicles, Heavy capacity forklift, Small/medium capacity forklift, ...

Contact Us

For more information, pricing, or custom solutions, please contact us:

Website: <https://www.indzawo.co.za>

Email: sales@indzawo.co.za

Phone: +27 71 296 8473

Address: 22 Quantum Street, Midrand, 1685, Gauteng, South Africa

This document is for informational purposes only. Specifications subject to change without notice.

